

GP9335C Series

LOW Frequency Online UPS

120-800KVA (3 Ph in/3 Ph out)

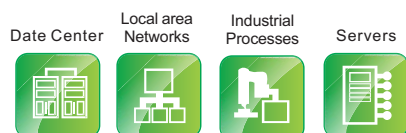

► Product snapshot:

Model: 120-800KVA
Nominal voltage: 380/400/415VAC
Nominal frequency: 50/60Hz
Output Power factor: 0.9
Parallel: maximum 6PCS UPS
Indicated language: 12 types (En.Ru.Sp.Fr...)
Efficiency Rate of Machine: $\geq 94\%$ ($\geq 98\%$ in ECO Mode)

Efficient • Energy-saving • Environmental-protection • Innovation :

GP9335C series UPS for China's top product, nominal capacity from 120KVA to 800KVA, had application in key equipment for the power system protection, could provide high quality power, with high level of availability and scalability, and invest minimize Total Cost of Ownership (TCO) .

Application:

Application Mainly used in large IDC rooms, bank/securities settlement center, communication network management center, semi-conductor product lines and large automation production with its control system. According to the special needs of users was improved, used in large sports venues, conference room, theater, highway and railway tunnels metal halide lamp lighting system.

Key Features:

- Use advanced 6th generation DSP and full digital control technologies to realize higher system stability.
- Output power factor is 0.9, carrying capacity than conventional UPS with 10% above, as users reduce investment cost.
- Advanced distributed active parallel technology can realize parallel operation of 6PCS UPS units without the need of centralized bypass cabinet.
- 6-inch extra large LCD that can display 12 language (Chinese ,English,Russian,Spanish,French and so on).
- Extra wide input voltage and frequency range make it adapt to severe power grid environment.
- Intelligent battery management maintains battery automatically to prolong the battery life.
- Standard input/output filter improves the system EMC performance.
- Extra strong capability to withstand output overload and short circuit, ensuring the system stability and system safety under extreme conditions.
- Layered independently-sealed ventilation channel and re-dundant fan, circuit boards with protective paints and a dust filter embedded make it highly efficient to dissipate heat and protect the product effectively under severe environment.

Excellent Electrical Performance:

Online double transform structure, double DSP control technology.

- GP9335C series UPS Using real online double transform structure. This architecture is currently the best to solve the power structure. The framework can almost completely solve all the power problems, such as power utility high and low voltage, voltage instantaneous fall, reduce oscillations, high-voltage pulsed, voltage fluctuation, surge voltage, harmonic distortion, clutter interference, frequency wave power supply problems. Provide continuous, stable and pure sine wave power for the load.

■ Adopt double DSP high speed digital signal processing chip collaborative central CPU microprocessor common to the system control, feedback, measuring, display, communication etc for all-round real-time processing, and make the system parameters keep the same when environment (temperature, humidity, noise, etc.) changes. Even in the input signal distorted, can also provide accurate current, voltage, frequency and waveforms output. This technology has powerful control functions, thus realizing the computer system's comprehensive power management.

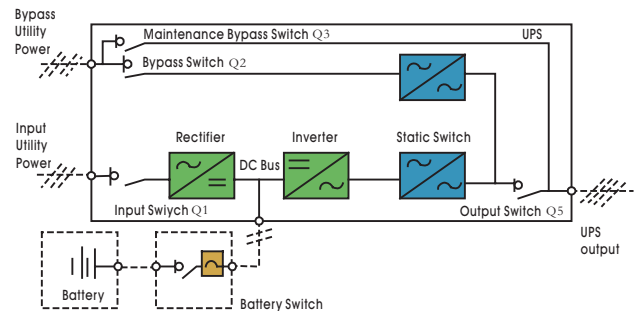

GP9335C Series Working Principle:

■ GP9335C series UPS use AC-DC - AC converter. The first level transform (AC - DC) adopts SCR 3-phases full controlled rectifiers, 3-phase AC input voltage transform into stable DC bus voltage. Rectifier hold concurrently and charger function, and adopts the advanced temperature compensation technology, so that prolong battery life. Inverter main power adopts high power insulation gate bipolar transistors (IGBT) as its inverter unit. Controller adopts advanced space vector pulse width modulation (SVPWM) technology. And the DC Bus voltage inverter back to AC voltage.

■ Rectifiers and inverter work at same time when the Utility Power is normal, at the same time to supply power to the load and to the battery charge. When the utility power anomalies, rectifier stop working, turn by the battery by inverter to power supply to the load. If the battery voltage drops to discharge the termination voltage, and utility power hasn't returned to normal, UPS will shutdown (if two utility power different source and bypass the normal, system will let bypass supply power). Battery discharge and terminate voltage already preset. Inverter fault or overload, still can have external communications bypass through bypass switch Q2 and static bypass to supply power for the load. In addition, if UPS need maintenance or repair, UPS can through internal manual control maintenance bypass switch Q3 to supply power to the load. UPS normal operation, except maintenance bypass switch, all other switches are closed.

Super output overload capacity :

Inverter power with a strong output overloads capacity, achieve "inversion state priority" thinking.

As we know, to measure the reliability of UPS power supply, one important indicator of the level that's strong anti-output overload. This means that when user put large non-linear load and form transient surge overload output situation, not only ensure the UPS inverter is intact, but will not overload the inverter output due to poor Bypass switch AC power supply situation. The reason is that when the UPS power supply in the implementation of the inverter AC bypass switch operation period, the City regulator may not have a regulated power supply and inverter power output characteristics of the transient voltage difference between too large to damage the UPS.

The typical overload capacity of ups as follow:

■ Three phase ups working:

110% rated load for one hour

125% rated load for ten minutes

150% rated load for one minute

■ Single phase ups working: 200% rated load for 30 seconds

■ When the user over load no more than the above range, UPS will continue to maintain the load by the inverter power supply status.

(Note: output power factor is 0.9)

With a strong anti-step of load and short circuit output capability :

UPS power supply operation in the worst working conditions encountered by the user in the UPS output load 100Ĉ rated load for the input or the removal operation. The most serious situation is that UPS output is short circuit. Since the SORO UPS, configure a unique design of the output current limiting circuit. Even if the user inadvertently caused by the output short-circuit fault, it's UPS inverter will not be damaged. Typical UPS output capacity of short circuit:

■ three-phase work, the output current is limited to 160% nominal output current, 5 seconds.

■ Single-phase operation, the output current is limited to 290% nominal output current, 5 seconds.

Superior ability with three phase unbalanced load :

For the three phase in/three phase out UPS, even with a peak in the ratio (crest ratio) is 3:1 in the non-linear loads like computers, they can't reduce the rated output power conditions and provide users with distortion less than 3-5% high-quality sine wave power. Moreover, as the machine is equipped with adaptive equilibrium adjustment circuit,

when followed 100Ĉ unbalanced load (one phase no-load, two phase full load), they can ensure that the three-phase phase voltage difference is less than 2Ĉ, and phase difference between the $120^\circ \pm 1^\circ$ ranges. This indicator was higher than similar products of other companies.

N + X redundant design of auxiliary power supply :

Controlled circuit of auxiliary power for each provide reliable, stable power protection so that ensure all the control circuit to work properly. To ensure the normal operation of UPS systems play a key role. GP9335C Series UPS's auxiliary power adopt 1+1 redundancy design, when one of the auxiliary power failure, can be continued by another auxiliary power supply. UPS continue to operate normally, while the LCD screen displays this warning message.

Unique battery protection function :

Battery and UPS by connecting an external battery switch, the battery switch is a "three-stage" DC switch that can be manually closed, and has a control circuit controlled by the UPS electronic tripping device. Effectively reducing the past due to battery leakage or short circuit caused the fire risk for the safe operation of the engine room has provided a guarantee. Battery switch has the following characteristics:

- And battery isolation, safe and reliable;
- Short-circuit protection;
- In case of battery voltage causes the inverter lock, then switch off automatically to avoid battery discharge damage;
- Fitted with a remote emergency stop button, emergency stop button can be used remotely disconnect the switch;
- Misuse protection;

Easy maintenance of structure design :

Using user-friendly control panel modular inline graphic design, to ensure reliable connection between the plug plates, the connection is configured with a connector locking mechanical "locking" device. Users simply open the cabinet door that can be observed a glance at the control panel of the UPS "self diagnosis" Status Monitor the work of the state. As a result, users can quickly access to nearly 70-90 species of fault alarm indication, and improve the maintainability of this UPS.

Efficiency, energy-saving, environmental protection design

The efficiency of machine is up to 94%:



Easy installation:

- layered freestanding obturator-ventilation
- Installed against the wall
- The favourable ventilation design
- Can pass in and out the cables from the top

- A** LCD Display

- B** Air Filter

- C** Electronic control PCB

- D** N+X assistant power supply PCB

- E** Battery monitor connect terminal

- F** 220V Socket

- G** Input power switch

- H** Bypass power switch

- I** Maintain bypass switch

- J** Output switch



DC BUS module



Input/output power distribution



N+X power module

Overview of large UPS equipment, efficiency, impact significantly on energy costs that percentage of minor differences can save considerable operating costs. Our design team from start improve efficiency and make a lot of effort. Especially for the actual operation of the load rate (example: 50% of the load operation, etc.) were carefully considered.

UPS load power	400KW		
Efficiency between the ups with other brands	4%	3%	2%
save power per hour (KW)	16	12	8
save time per year (H)	8760	8760	8760
save power per year (KW H)	140160	105120	70080
the electricity price (RMB)	0.8	0.8	0.8
save fees of electricity per year (RMB)	112128	84096	54064
save fees for five years (RMB)	560640	420480	280320

Note: This series of ups machine efficiency is 94%, ECO mode 98%, other brands of domestic power ups efficiency of the unit segment is 80 ~ 90%.

Clean stable output waveform:

output voltage curve 1% change in the sine envelope line digital pulse-width modulation with free frequency 250% 200% 120% 100% Rotating UPSSCR-based UPSTransistor-based UPS GP9335C UPS Power Demands Non-linear load 100% To ensure the non-linear load voltage distortion $\leq 3\%$ the min capacity of kinds of ups need:

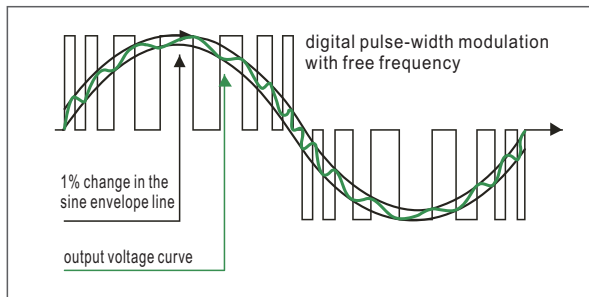
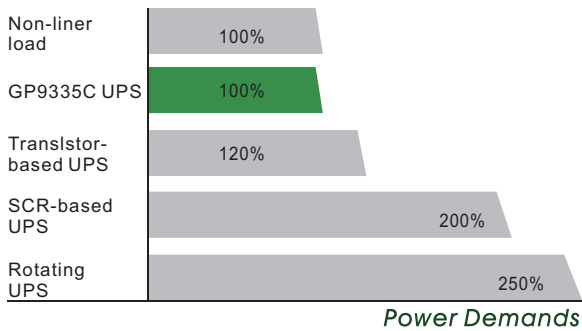

High input power factor level, harmonic distortion cancellation: save cost of energy consumption, reduce power pollution :

As well-known, the rectifier filtering load (such as computer, communication equipment, appliances or general UPS) was introduced to power grid largely and the power grid will be polluted, higher harmonic current that caused by pollution through the whole power supply system. Overcurrent that flow past mid line and motor load are heat abnormally. To

deal with those problems, we provide some solutions to eliminate the harmonic pollution so that ensure quality of power reach the standard of Green power:

GP9335C series are adopted optional input filter and 12 pulses rectifier filter, the solution improves the input power factor to above 0.95, reduce the input harmonic current to 10%.

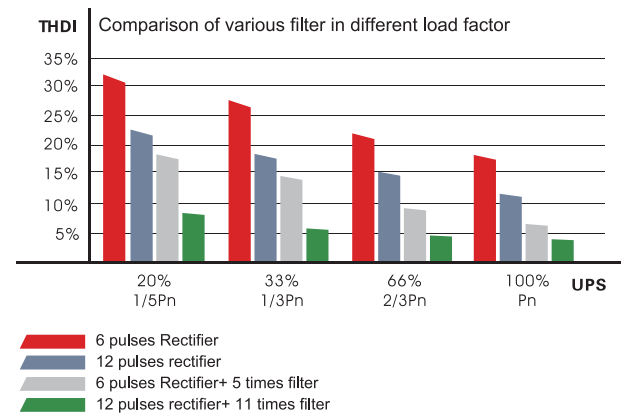

It is true that the 5 times filter is the largest in 6 pulses rectifier, and it can retrofit filter 5 times to restrain harmonic. 11 times is the largest in the 12 pulses rectifier and it can retrofit filter 11 times to restrain harmonic. Correlation table for harmonic after retrofitting filter as follows:

Harmonic times	6pulses rectifier	6 pulses Rectifier +5 times filter	12 pulses rectifier	12 pulses Rectifier +11 times filter
5	32	2	1	1
7	3	1	1	1
11	8	7	9	3
13	3	2	4	2
17	4	3	1	1
19	2	2	1	1

harmonic suppression impact obvious with filter

Core of high available configuration Great parallel output features

There are frequency busbar and current busbar in parallel control system, they can control each UPS phase relation and flow equalize output feature. So the system not only ensure each UPS located in general UPS power supply can share load current, but also it can reduce the circulation maybe happened in parallel system to zero.

Moreover, because of sensitive circulation survey, it can survey the operative mode of UPS power supply system constantly and with high reliability (MTBF reach to 1 million hours), it is the top level in the similar type

High reliable UPS Power Solutions:

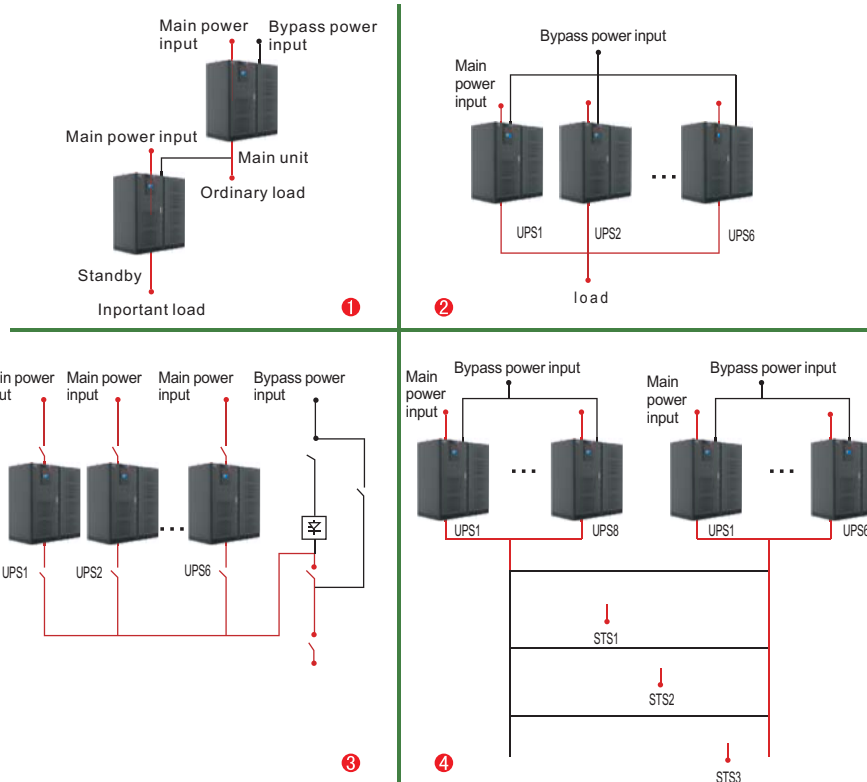

① Hot back-up redundant system. Adopt two sets high reliable GP9335C series UPS, spare UPS in series with bypass of the main UPS. Main and spare UPS can work alternately.

② N + 1 directly parallel redundant system. Up to six modules in parallel. Any one can drop out when it fault. Load power supply was not affected. Autobypass and maintenance bypass are built in each UPS.

③ N + 1 concentration bypass parallel redundant system. Many GP9335C series UPS in parallel, Any one can drop out when it fault. Load power supply was not affected. No bypass in the each interior, adopts concentration bypass.

④ Parallel double bus system with STS static transfer switch. Double bus system adopts redundant UPS design, improves system's reliability and availability.

The rate is either N or N+1 for each bus UPS capacity and the relative load.

Abundant Management Interface Convenient for observation and easy-to-use display system

By LED light emitting diode constitute UPS power simulation operational process Chart with LCD screen that form the people-machine conversing menu which display UPS operation parameters and alarm/fault. This operation control of the display system is readable and easy to operate and see. Due to the design high-tech microprocessor monitoring technology, advanced "Self-diagnosis" management system and built-in Storage Unit. Therefore, users can be easily obtained as follows UPS operation information:

2. UPS monitoring system provide users all kinds of real-time operation parameters (input voltage and current, output voltage and current, working frequency, load percentage, apparent power and active power, battery voltage and current, temperature, etc.). Intelligent fault "Self-diagnosis" management system can provide up to 90 kinds alarm/fault information. This information is based on "control simulation screen" the words on the display and sound alarm a variety of forms such as simultaneously to the user notification, and also shows which happened alarm/fault the properties, types and time of occurrence. Obviously, this is very helpful in the user for failure analysis and exclusions, so that greatly improve UPS maintainability.

3. Using the programmable automatic test software for UPS itself and batteries executes preventive functional testing, and shows the remaining battery capacity. This is helpful to discover in time and eliminating fault hidden trouble.

4. Using RS232 or RS485 and auxiliary power supply monitoring software, in our company UPS systems, the UPS in remote parameter display the microcomputer and computer terminals on the network. When abnormality, it can also display historical data and fault occurred frequency statistics in the computer terminal for analysis.

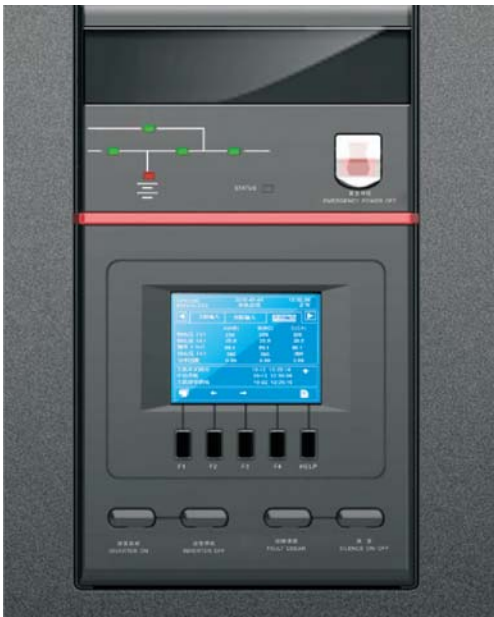

LCD display

A、UPS information

- UPS name.
- UPS model.
- Current time and date.
- Local number for parallel UPS system.
- UPS warning information.

B、Live data

Parameters as below shall be displayed in the LCD screen. All the displayed electric parameters shall be updated one time per 5 seconds. The error less than 2% between display number and the real number.

- Main circuit input

Three phase main circuit input voltage.
Three phase main circuit input current.
Three phase main circuit input frequency.
Three phase main circuit input power factor.

- Bypass input

Three phase bypass input voltage.
Bypass input frequency.

- UPS output

Three phase output voltage.
Three phase output current.
Three phase power factor.
Three phase output frequency.

- Load information

Three phase load percent.
Three phase active power, apparent power.
Load power factor.

- Battery

Battery voltage.
Battery current.
Battery backup time prediction.
Environment/ temperature.
Battery capacity.

- Load for starting up

Three phase total apparent power.
Three phase total active power.
Three phase total reactive power.

C. Records for historical events

- Update Records for Historical events immediately when the fault occurs.
- It can records 10000 historical events at the most.

D. Menu language

12 languages

E. Set information is permitted

- Date format.
- Date and time.
- Communication address.
- Communication mode.
- Com1 baud rate.
- Com2 baud rate.
- Com3 baud rate.
- Telephone.

F. Control interface

- Start battery maintenance self-testing.
- Start system self-testing.
- End up testing.

Perfect Battery Management System

■High performance battery management consists of charging technology with “constant-current then constant voltage” features and battery monitoring software with strong development function. Excellent performances for the regulate system as follows:

Charging current-limiting technology is adopted, overcurrent charging will not appear.

■To refuse discharge deeply, it adopt microprocessor monitoring technology that can adjust threshold level of battery’s discharge voltage automatically according to users’ real capacity.

■Programmable battery monitor software can execute self-diagnosis test regularly and display battery charging capacity and backup time automatically.

■Supply battery charging system with temperature compensation and automatic regulation functions.

■Equipped with battery overvoltage charging protection and automatic equalized charging timing controller.

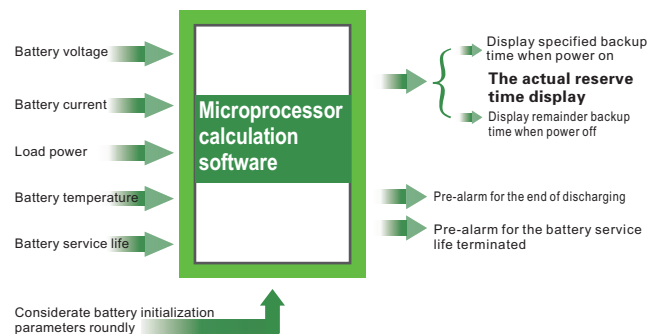

Initial voltage E_0 , initial internal resistance R_0 , initial temperature T_0 , Initial capacity C_{10} , discharge coefficient k_1-k_2 , charging coefficient $\alpha_1-\alpha_2$ Quantity for Series connection and parallel, cut-off voltage.....

Unique Option, One-stop Service

- SNMP card
- Parallel card
- Dry contact card
- C class lighting protection case
- Outlet option
- Bypass flow equalize inductance
- Battery temperature transmitter
- JBUS/MODBUS interface card
- UPS generator room signal adapter
- 5 times harmonic or 11 times harmonic filter
- Load busbar synchronization (LBS) cable

UPS Power Solutions Expert

GP9335C Series Technical Specifications

Model	GP9335C 120-800KVA															
	6P	12P	6P	12P	6P	12P	6P	12P	6P	12P	12P	12P				
Rated Nominal	120KVA/108KW		160KVA/144KW		200KVA/180KW		300KVA/270KW		400KVA/360KW		500KVA/450KW		600KVA/540KW		800KVA/720KW	
Rated Input Voltage	380/400/415VAC 3-phase 4-wire															
Rated Frequency	50/60HZ															
Input Parameters																
Input Voltage Range	± 25%															
Input Frequency Range	45Hz ~ 65Hz															
Input Soft Start Function	0-100% 5-300S settable															
Input Power Factor	> 0.98 (If harmonic filter is added)															
Input harmonic current(THDi)	< 4.5% (If harmonic filter is added)															
Bypass																
Bypass Voltage Range	-20% ~ +15%															
Bypass Frequency Range	50/60HZ±10%															
Output Parameters																
Inverter Output Voltage	380/400/415VAC 3-phase 4-wire															
Voltage Stability	±1%(Steady status),±3%(Transient status)															
Frequency	50/60Hz															
Mains power synchronization window	± 5%															
Actually measured frequency accuracy (internal clock)	50/60Hz±0.05Hz															
Output Power Factor	0.9 (Output 90kW per 100kVA)															
Transient Response Time	<5ms															
Inverter Overload Capability	At 0.9 power factor, 110% for 1 hour, 125% for 10 minutes and 150% for 60s															
Short circuit current from inverter	3ph 1.5In for 5seconds, 1ph 2.9In for 5seconds															
DC Voltage	360/384/432/480VDC															
Maximum Bypass Capability	1000% for 100ms															
Phase Shift Characteristic	With 100% balanced load		<1°													
	With 100% imbalance load		<1°													
Total Harmonic Distortion(THDv)	100% linear load		<1%													
	100% non-linear load		<3%													
System Efficiency (full load)	Up to 94% (inverter efficiency is up to 98%)															
Rectifier Output Parameters																
Charger output voltage stability	1%															
DC Ripple Voltage	≤1%															
Operating Environmen																
Operating Temperature Range	0 ~ 40°C															
Storage Temperature	-25 ~ 70°C (inverter efficiency is up to 98%)															
Relative Humidity	0 ~ 95% (Non-condensing)															
Maximum Operating Height	≤Elevation 1000m, for elevation above 1000m, derate by 1% for every increase of 100m															
Noise (1m)	58-68dB															
Protection level	IP20															
Standard	Safety: IEC60950-1 IEC62040-1-1 UL 1778 EMC IEC62040-2 CLASS C2 EN50091-2 CLASS A Design and Test IEC62040-3															
Physical Parameters																
Weight(Kg)	980	1420	1200	1750	1350	2000	1600	2200	2100	2750	3690	6390	7390			
Dimension (W x D x H)mm	900X855X1900	1250X855X1900	1640X855X1900	1250X855X1900	1640X855X1900	2280X855X1900	2835X1000X1950	3955X1090X1950								

STANDARD: Conform to GB/IEC regulation : EMC:GB7260.2/IEC62040 GB/17626.2~5/IEC61000-4-2~5 SAFETY:GB4943

Note:Product specifications are subject to change without further notice.